

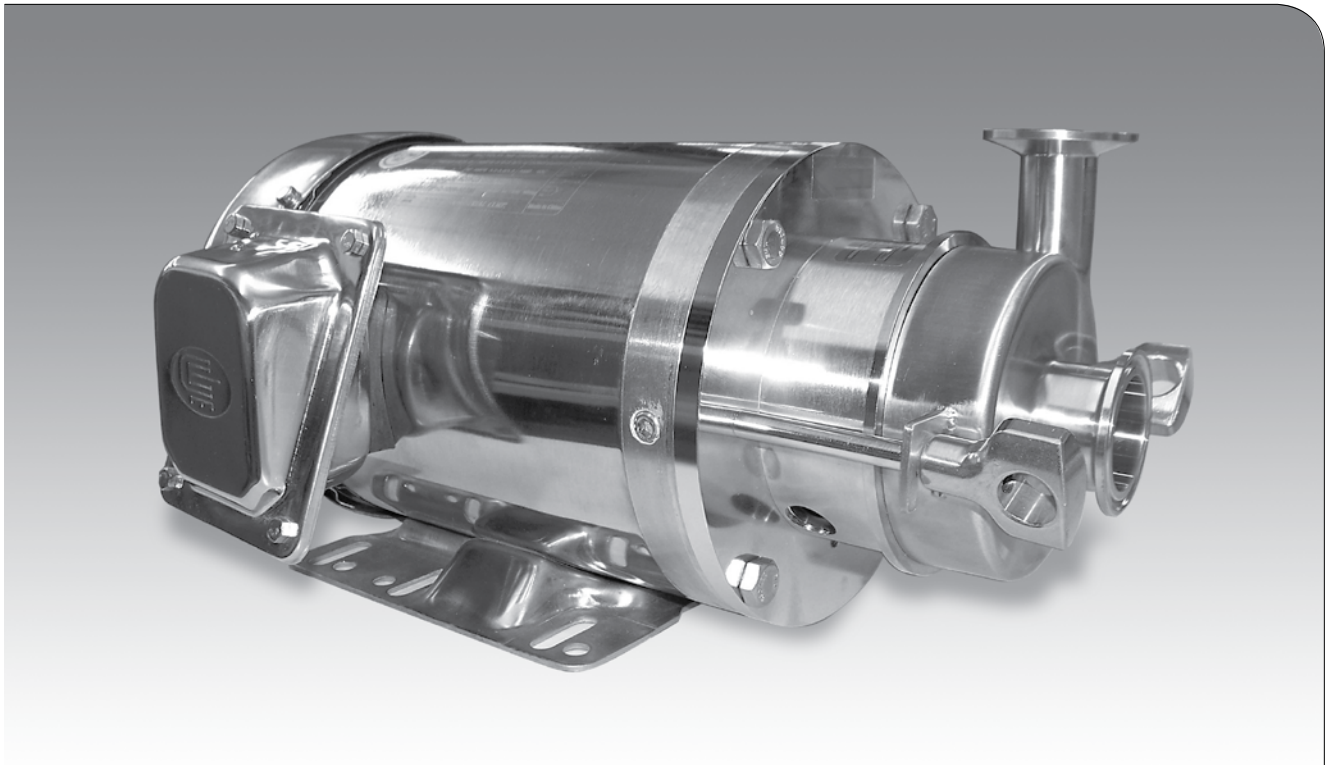

C-100 Pump



Stainless Steel Flow Control Equipment for the
Food, Beverage, Dairy, Cosmetics, Biotechnology,
Pharmaceutical and Electronics Processing Industries

Top-Flo® TF-C100 Centrifugal Pump

The TOP-FLO® TF-C100 centrifugal pump is ideal for use in small and medium size process applications in the dairy, food, beverage, pharmaceutical and other sanitary process industries.

Specifications

- Pump Casing
 - Circular Type
- Pump Connections
 - 1 1/2" Inlet x 1" Outlet
 - Clamp type - Standard
- Pump Construction materials
 - All Wetted Parts - Type 316L
 - Balance Type 304
 - Carbon Seal
 - O-Ring & Casting Gasket - FDA Buna
- 3A Approved
- Pump Finish
 - Polished ID/OD 32Ra
- Pump Impeller
 - Max 3.685" Diameter
- Pump Seal
 - External Balanced
 - Sanitary Single Mechanical

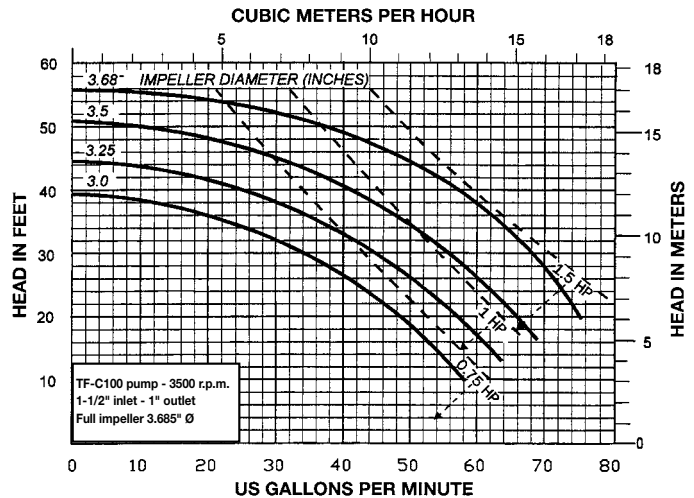
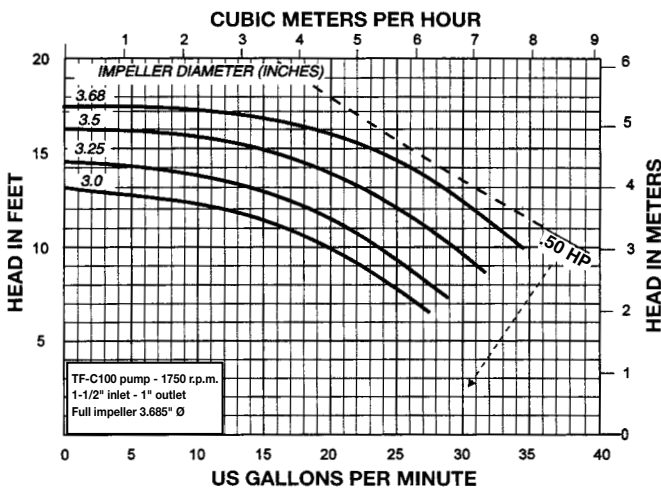
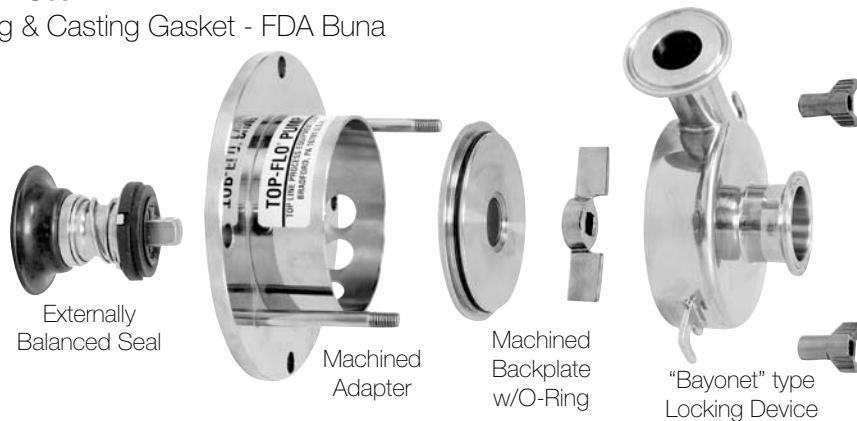

*Styles and dimensions are subject to change without notice.



... the source for
all your product needs
in the process industries

Contact your Top Line Representative for Assistance
Office: P.O. Box 264 · Bradford, PA 16701

Plant: 21 Valley Hunt Drive · Lewis Run, PA 16738

Phone: 800-458-6095

814-362-4626

Fax: 814-362-4453