

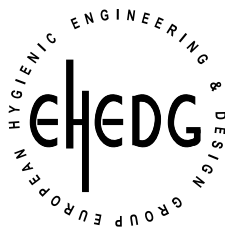

World's First Sanitary
Mag Drive Pump



Manufactured
for Top Line by
CP PUMPEN
Switzerland

For the Pharmaceutical, Biotech & Food Industries

www.toplineonline.com

Sanitary Magnetic Drive Pump

The newly developed Series MKP-Bio offers you an excellent solution for aseptic applications in the pharmaceutical, biotech, food industry and other sanitary processes.

The pump has been developed and designed according to the EHEDG recommendations and takes in to account VDMA 24432 and EN 12462 standards.



TECHNICAL DATA

Capacity	Q:	up to 20 m ³ /h 220 GPM
Head	H:	up to 260 ft.
Temp	°F:	-72 up to 300°F
Nom. Pres.	PN:	230 PSI
Materials		316L S/S, Hast. C22, Alloy 59 Further materials available on request.
Execution		Vertical / close coupled

FEATURES

- Vertically mounted Magnetic Drive Pump with patented drive system.
- The pump is totally self-draining through the suction connection eliminating requirement for additional flush drain and vent connections.
- Due to the inherent design of the internal bearing lubrication and the gasket construction according to DIN 11864, the pump is deadspace free.
- Specially designed flushing in the internal bearing guarantees excellent lubrication and cooling.
- All wetted components meet a surface finish of min. 32ra standard, other finishes available on request.
- All wetted corners are radiused for complete drainability.
- All wetted surfaces are finished with a minimum 3° slope.
- Microorganism cannot enter from the atmosphere into the pump.
- CIP/SIP - able in place.
- Reliable and easy assembly and reassembly.
- For assembly and reassembly of the pump there is no special tool required.
- All wetted materials are made of FDA approved components.
- Slurry content up to 10% max. 0.03"

OPTIONS

- Internal bearing in tungsten carbide
- Diamond coated internal bearing
- Jacketed casing
- Temperature protection sensor PT-100 (recommended) to protect against dry running
- Double shroud system
- Special frame mounting
- Special O-ring material available on request (Viton®, EPDM, Silicone).
- Different suction - and discharge - connections available (clamp, T-I-Live, flange and butt weld)

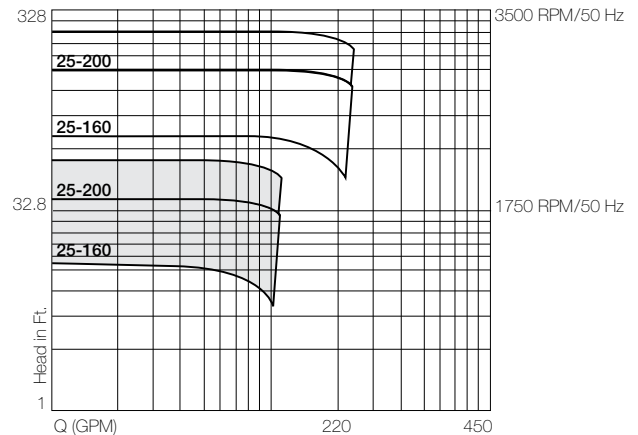
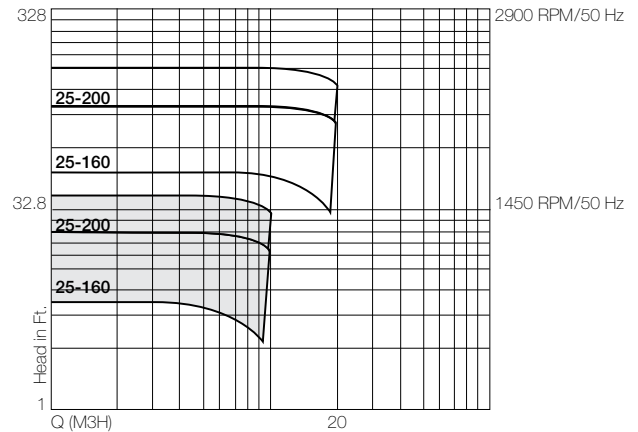

TOP LINE
PROCESS EQUIPMENT COMPANY

. . . the source for
all your product needs
in the process industries

Contact your Top Line Representative for Assistance
Office: P.O. Box 264 · Bradford, PA 16701

Plant: 21 Valley Hunt Drive · Lewis Run, PA 16738

Phone: 800-458-6095

814-362-4626

Fax: 814-362-4453

www.toplineonline.com