



## Top-Flo<sup>®</sup> TL60ARV Air Relief Valve



Stainless Steel Flow Control Equipment for the  
Food, Beverage, Dairy, Cosmetics, Biotechnology,  
Pharmaceutical and Electronics Processing Industries

# TL60ARV Air Relief Valve

The TL60ARV Air Relief Valve is used primarily when removal of air from a line without loss of product is a concern. The design of the TL60ARV is simple: a ferrule, a housing with a plastic ball, and a vent pipe all connected using 2 standard heavy duty clamps. This design will not let air enter the line or container under negative pressure.

The TL60ARV is double seated. The lightweight ball is freely moving and depending on pressure conditions will close against upper or lower seat. This valve is not designed for use in operation with liquids having less than 1.0 specific gravity.

The valve can be mounted on the top of a pipeline or container to bleed a pipeline where an air pocket may have formed during operation.

Bleeding a pipe on the suction side of a pump will be automatic. Air binding will be prevented.

These valves are found mounted on the top of the inlet pipe in front of the pump.

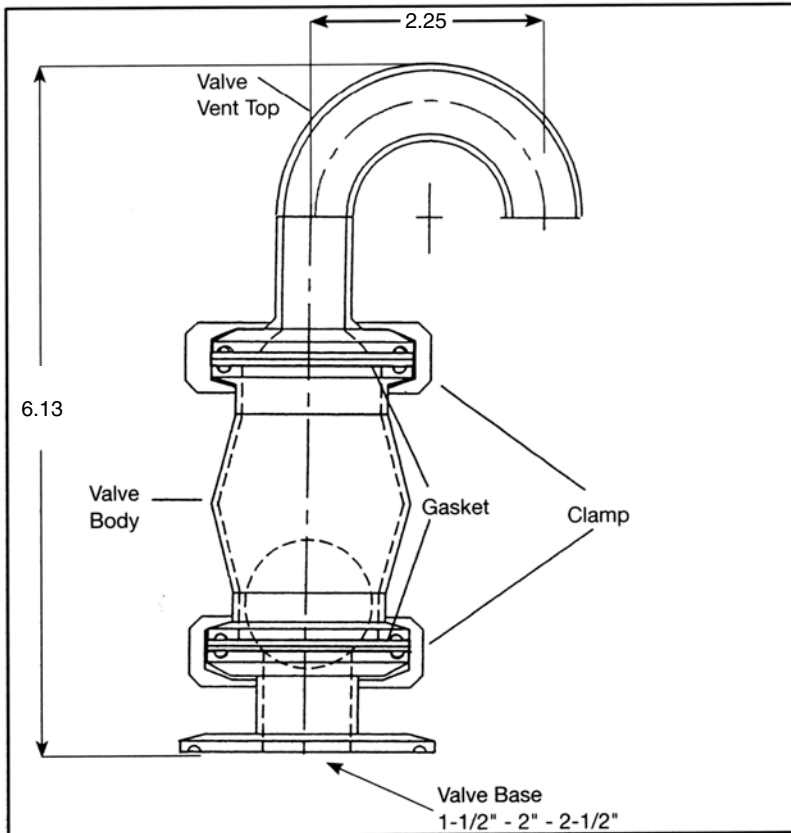

TL60 ARV Air Relief Valve 1-1/2"		
Description	Part Number	Qty.
1-1/2" TL60ARV	386015ARV	
Vent Top	38601525VT	1
Body	38601525	1
Base - 1-1/12"	386015	1
Clamp	3299915	2
Gasket (Viton)	321010V	2
Ball	38601525B	1

TL60 ARV Air Relief Valve 2"		
Description	Part Number	Qty.
2" TL60ARV	386020ARV	
Vent Top	38601525VT	1
Body	38601525	1
Base - 2"	386020	1
Clamp	3299915	2
Gasket (Viton)	321010V	2
Ball	38601525B	1

TL60 ARV Air Relief Valve 2-1/2"		
Description	Part Number	Qty.
2-1/2" TL60ARV	386025ARV	
Vent Top	38601525VT	1
Body	38601525	1
Base - 2-1/2"	386025	1
Clamp	3299915	2
Gasket (Viton)	321010V	2
Ball	38601525B	1

**Ordering Information**

Steel grade .....Stainless steel, AISI 316L  
 Ball.....Polypropylene  
 Finish .....Polished to 32RA

**Technical Data**

Maximum product pressure ..... 150 PSI  
 Maximum temperature .....275°F  
 Net weight .....19 oz. (9.5 kg)  
 For proper operation:  
 • Product density must be 1.0 or higher  
 • The valve must be mounted vertically



... the source for  
 all your product needs  
 in the process industries

Contact your Top Line Representative for Assistance  
 Office: P.O. Box 264 · Bradford, PA 16701

Plant: 21 Valley Hunt Drive · Lewis Run, PA 16738

Phone: 800-458-6095

814-362-4626

Fax: 814-362-4453